



# Mini cylinder(Stainless steel)——MA Series

## Product series

Series name	Mounting type				Acting type	Bore size	Collocation of sensor switch									
	Basic	LB	FA	SDB			CS1-M	DS1-M	CS1-F	DS1-F	CS1-U	DS1-U				
Double acting type: MA Double acting with adj. cushion:MAC	●	●	●	●	Double acting Double acting (with adj.cushion)	16	●	●								
Single acting type: MSA, MTA	●	●	●	●		Single acting	20	●	●							
	●	●	●	●			25	●	●							
Double rod type: MAD, MACD	●	●	●		Double acting Double acting (with adj. cushion)	32	●	●								
Adjustable stroke type: MAJ, MACJ	●	●	●			40	●	●								
	●	●	●				50	●	●	●	●	●	●	●	●	●
Other series: MAR	●	●	●		Double acting Double acting (with adj. cushion)	63	●	●	●	●	●	●	●	●	●	
	●	●	●			20	●	●								
	●	●	●			25	●	●								
	●	●	●			32	●	●								
	●	●	●			40	●	●								
						50	●	●	●	●	●	●	●	●	●	
						63	●	●	●	●	●	●	●	●	●	

Page	228	233	397
------	-----	-----	-----

## Installation and application

- When load changes in the work, the cylinder with abundant output capacity shall be selected.
- Relative cylinder with high temperature resistance or corrosion resistance shall be chosen under the condition of high temperature or corrosion.
- Necessary protection measure shall be taken in the environment with higher humidity, much dust or water drops, oil dust and welding dregs.
- Dirty substances in the pipe must be eliminated before cylinder is connected with pipeline to prevent the entrance of particles into the cylinder.
- The medium used by cylinder shall be filtered to 40 μm or below.
- Anti-freezing measure shall be adopted under low temperature environment to prevent moisture freezing.
- The cylinder shall be carried out test run without load before application. Prior to run, buffer shall be turned to the minimum and gradually released to avoid the damage on cylinder caused by excessive impact.
- To avoid side load, otherwise, piston rod will be bent and deformed and damage the thread at the end of the rod. Single-acting type can not be added in return.
- If the cylinder is dismantled and stored for a long time, please to conduct anti-rust treatment to the surface. Anti-dust caps shall be added in air inlet and outlet ports. The front and back cover can not be dismantled, which shall be especially noticed.

Please Click Page Code

## Criteria for selection: Cylinder thrust

Unit: Newton(N)

Bore size (mm)	Rod size (mm)	Acting type	Pressure area (mm <sup>2</sup> )	Operating pressure(MPa)							
				0.1	0.2	0.3	0.4	0.5	0.6	0.7	
16	6	Single acting	Push side	201.0	-	-	20.1	40.2	60.3	80.4	100.5
			Pull side	172.7	-	-	11.6	28.9	46.2	63.4	80.7
		Double acting	Push side	201.0	20.1	40.2	60.3	80.4	100.5	120.6	140.7
			Pull side	172.7	17.3	34.5	51.8	69.1	86.4	103.6	120.9
20	8	Single acting	Push side	314.0	-	15.7	47.1	78.5	109.9	141.3	172.7
			Pull side	263.8	-	5.7	32.0	58.4	84.8	111.2	137.5
		Double acting	Push side	314.0	31.4	62.8	94.2	125.6	157.0	188.4	219.8
			Pull side	263.8	26.4	52.8	79.1	105.5	131.9	158.3	184.7
25	10	Single acting	Push side	490.6	-	24.6	73.7	122.8	171.8	220.9	269.9
			Pull side	412.1	-	8.9	50.1	91.4	132.6	173.8	215.0
		Double acting	Push side	490.6	49.1	98.1	147.2	196.2	245.3	294.4	343.4
			Pull side	412.1	41.2	82.4	123.6	164.8	206.1	247.3	288.5
32	12	Single acting	Push side	804.3	-	40.2	120.6	200.9	281.3	361.7	442.1
			Pull side	691.2	-	17.6	86.6	155.7	224.8	293.9	363.0
		Double acting	Push side	804.3	80.4	160.9	241.3	321.7	402.2	482.6	563.0
			Pull side	691.2	69.1	138.2	207.4	276.5	345.6	414.7	483.8
40	16	Single acting	Push side	1256.6	-	62.8	188.4	314.0	439.6	565.2	690.8
			Pull side	1055.6	-	22.6	128.1	233.6	339.1	444.6	550.1
		Double acting	Push side	1256.6	125.7	251.3	377.0	502.6	628.3	754.0	879.6
			Pull side	1055.6	105.6	211.1	316.7	422.2	527.8	633.4	738.9
50	16	Double acting	Push side	1962.5	196.3	392.5	588.8	785.0	981.3	1177.5	1373.8
			Pull side	1761.5	176.2	352.3	528.5	704.6	880.8	1056.9	1233.1
63	16	Double acting	Push side	3115.7	311.6	623.1	934.7	1246.3	1557.9	1869.4	2181.0
			Pull side	2914.7	291.5	582.9	874.4	1165.9	1457.4	1748.8	2040.3



# Mini cylinder(Stainless steel)

## MA Series



### Specification

Bore size(mm)		16	20	25	32	40	50	63	
Acting type	MSA, MTA	Single acting						-	
	MA, MAD, MAJ	Double acting						-	
	MAR	Double acting						-	
	MAC, MACD, MACJ	Double acting with cushion						-	
Fluid		Air(to be filtered by 40 μ m filter element)							
Operating pressure	Double acting	0.1~1.0MPa(15~145psi)(1.0~10.0bar)							
	Single acting	0.2~1.0MPa(28~145psi)(2.0~10.0bar)							
Proof pressure		1.5MPa(215psi)(15bar)							
Temperature °C		-20~70							
Speed range mm/s		Double acting: 30~800 Single acting: 50~800							
Stroke tolerance		0~150 <sup>+1.0</sup> <sub>0</sub> >150 <sup>+1.4</sup> <sub>0</sub>							
Cushion type		MAC, MACD, MACJ Series: Adjustable cushion						Other series: Bumper	
Port size ①		M5 × 0.8		1/8"			1/4"		

① PT thread, NPT thread and G thread are available. Add) Refer to P397~420 for detail of sensor switch.

### Stroke

Bore size (mm)	Standard stroke (mm)													Max. std stroke	Max. stroke	Bore size (mm)	Standard stroke (mm)											
	16	20	25	32	40	50	63	80	100	125	150	160	175				200	250	300	350	400	450	500					
MA	-	16	25	50	75	80	100	125	150	160	175	200	250	300	350	400	450	500	500	600	MSA	16	25	50	75	100		
	MAC	20	25	50	75	80	100	125	150	160	175	200	250	300	350	400	450	500	500	800		20	25	50	75	100	125	150
	MAR	25	25	50	75	80	100	125	150	160	175	200	250	300	350	400	450	500	500	800		25	25	50	75	100	125	150
	-	32	25	50	75	80	100	125	150	160	175	200	250	300	350	400	450	500	500	800		32	25	50	75	100	125	150
	-	40	25	50	75	80	100	125	150	160	175	200	250	300	350	400	450	500	500	800		40	25	50	75	100	125	150
	-	50	25	50	75	80	100	125	150	160	175	200	250	300	350	400	450	500	500	800		40	25	50	75	100	125	150
MAD MAJ	-	63	25	50	75	80	100	125	150	160	175	200	250	300	350	400	450	500	500	800	MTA	16	25	50	75	100		
	MACD	20	25	50	75	80	100	125	150	160	175	200	250	300	300	-	20	25	50	75		100						
	MACJ	25	25	50	75	80	100	125	150	160	175	200	250	300	300	-	25	25	50	75		100						
	-	32	25	50	75	80	100	125	150	160	175	200	250	300	350	400	450	500	500	-		32	25	50	75	100		
	-	40	25	50	75	80	100	125	150	160	175	200	250	300	350	400	450	500	500	-		40	25	50	75	100		
	-	50	25	50	75	80	100	125	150	160	175	200	250	300	350	400	450	500	500	-		40	25	50	75	100		
-	63	25	50	75	80	100	125	150	160	175	200	250	300	350	400	450	500	500	-	40	25	50	75	100				

Note) Consult us for non-standard stroke.

### Symbol

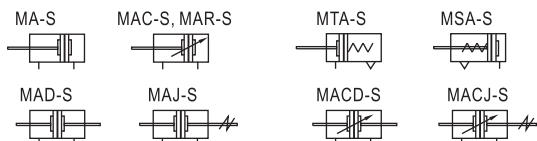

### Ordering code

MA	20 × 50	S	CM	<input type="checkbox"/>	<input type="checkbox"/>
MAD	20 × 50	S		<input type="checkbox"/>	<input type="checkbox"/>
MAJ	20 × 50-20 S			<input type="checkbox"/>	<input type="checkbox"/>
MAR	U 20 × 50	S		<input type="checkbox"/>	

### Product feature

- Standard cylinder manufactured by our enterprise.
- Piston adopts heterogeneous two-way seal structure. It has compact size and has the function of grease reservation.
- Front cover has fixed bumper which can reduce the impact of direction change of the cylinder.
- There are several modes of back cover, which makes the installation of cylinder more convenient.
- Front and back cover and stainless steel block adopt riveted rolling packed structure to form a reliable connection.
- The cylinder body has stainless steel pipes with high precision to produce high strength and corrosion resistance.
- There are cylinders and mounting accessories with several specifications for your choice.
- All cylinders of this series have magnet.

<b>Model</b>	MA: Mini cylinder(Double acting) MSA: Mini cylinder(Single acting_push) MTA: Mini cylinder(Single acting_pull) MAD: Mini cylinder(Double rod) MAJ: Mini cylinder(Adjustable stroke) MAR: Mini cylinder(Double acting with cushion) MAC: Mini cylinder(Double acting with cushion) MACD: Mini cylinder(Double rod with cushion) MACJ: Mini cylinder(Adjustable stroke with cushion)	<b>Thread type</b> ②	Blank: PT T: NPT G: G
<b>Front cover</b>	Model Front cover MAR F: Front mounting type U: Up mounting type Others No this code	<b>Mounting type</b> ①	Model Mounting type MA Blank: No accessories MAC FA: FA type MSA SDB: SDB type MTA LB: LB type MAD Blank: No accessories MACD FA: FA type MAJ LB: LB type MACJ LB: LB type MAR No this code
<b>Bore size</b>	Model Bore size MA, MSA, MTA, MAD, MAJ 16 20 25 32 40 MAC, MAR, MACD, MACJ 20 25 32 40 50 63	<b>Back cover</b>	Model Back cover MA, MAC CA: Pivot type MSA U: Flat-end type MTA CM: Round-end type Others No this code
<b>Stroke</b>	Refer to stroke table for details	<b>Magnet</b>	S: With magnet
		<b>Adjustable stroke</b>	Model Adjustable stroke 10: 10mm 20: 20mm 30: 30mm 40: 40mm 50: 50mm 75: 75mm 100: 100mm Others No this code

① Please refer to page 233 for accessory parts.

② Standard thread is blank here.



# Mini cylinder(Stainless steel)

## MA Series

### Inner structure and material of major parts

MA-CA

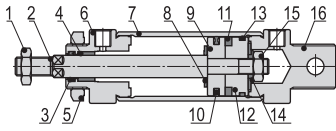

NO.	Item	Material
1	Rod nut	Carbon steel
2	Piston rod	Carbon steel with 20 μ m chrome plated
3	Front cover packing	NBR
4	Bushing	Wear resistant material
5	Front cover nut	Carbon steel
6	Front cover	Aluminum alloy
7	Barrel	Stainless steel
8	Bumper	NBR
9	Piston	Aluminum alloy
10	Piston seal	NBR
11	Magnet	Plastic
12	Magnet holder	Aluminum alloy
13	Wear ring	Wear resistant material
14	Washer	Free cutting material
15	Nut	Carbon steel
16	Back cover	Aluminum alloy

### Dimensions

MA Φ16-Φ40  
MAC Φ20-Φ40

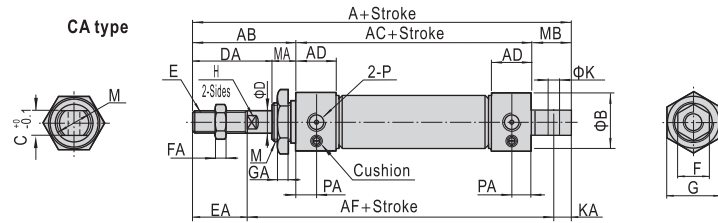

CM type

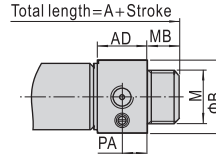

U type

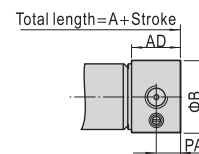

Bore size\Item Back cover	A			AB	AC	AD	AF	B	C	D	DA	E	EA
	CA	CM	U										
16	114	114	98	38	60	10	91	21	12	6	22	M6 × 1.0	16
20	137	128	116	40	76	16	108	27	16	8	28	M8 × 1.25	20
25	141	134	120	44	76	16	110	30	16	10	30	M10 × 1.25	22
32	147	134	120	44	76	16	113	35	16	12	30	M10 × 1.25	22
40	149	136	122	46	76	16.5	113	41.5	20	16	32	M12 × 1.25	24

Bore size\Item Back cover	F	FA	G	GA	H	K	KA	M	MA	MB		P	PA
										CA	CM		
16	10	5	22	6	5	6	9	M16 × 1.5	16	16	16	M5 × 0.8	5
20	12	6	29	7	6	8	12	M22 × 1.5	12	21	12	1/8"	8
25	17	6	29	7	8	8	12	M22 × 1.5	14	21	14	1/8"	8
32	17	6	32	8	10	10	15	M24 × 2.0	14	27	14	1/8"	8
40	17	7	41	9	14	12	15	M30 × 2.0	14	27	14	1/8"	8

MAC Φ50, Φ63

CA Type

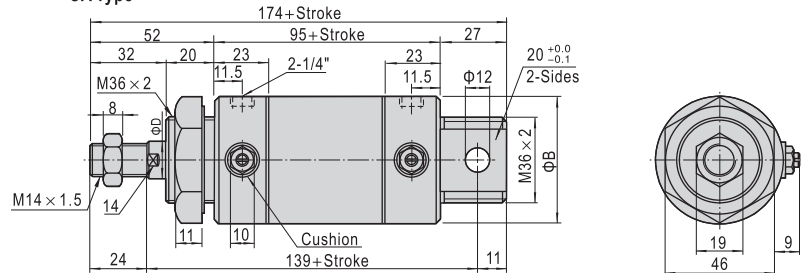

CM Type

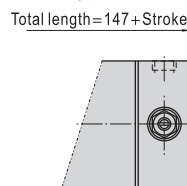

U Type

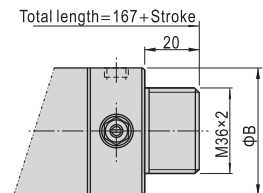

Bore size\Item	B	D
50	53	16
63	67	16



# Mini cylinder(Stainless steel)

## MA Series

MSA  $\Phi 16\sim\Phi 40$

CA Type

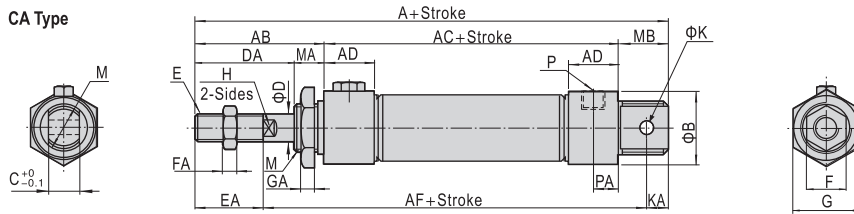

CM Type

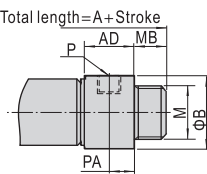

U Type

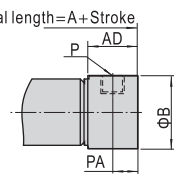

Item	CA		A			U			AC			AD		AF			
Back cover	CA		CM			U			AC			AD		AF			
Bore size\Stroke	≤50	51~100	≥101	≤50	51~100	≥101	≤50	51~100	≥101	≤50	51~100	≥101	≤50	51~100	≥101		
16	139	164	-	139	164	-	123	148	-	38	85	110	-	10	116	141	-
20	162	187	212	153	178	203	141	166	191	40	101	126	151	16	133	158	183
25	166	191	216	159	184	209	145	170	195	44	101	126	151	16	135	160	185
32	172	197	222	159	184	209	145	170	195	44	101	126	151	16	138	163	188
40	174	199	224	161	186	211	147	172	197	46	101	126	151	16.5	138	163	188

Bore size\Item	B	C	D	DA	E	EA	F	FA	G	GA	H	K	KA	M	MA	MB	P	PA	
Back cover	B	C	D	DA	E	EA	F	FA	G	GA	H	K	KA	M	MA	CA	CM	P	PA
16	21	12	6	22	M6×1.0	16	10	5	22	6	5	6	7	M16×1.5	16	16	16	M5×0.8	5
20	27	16	8	28	M8×1.25	20	12	6	29	7	6	8	9	M22×1.5	12	21	12	1/8"	8
25	30	16	10	30	M10×1.25	22	17	6	29	7	8	8	9	M22×1.5	14	21	14	1/8"	8
32	35	16	12	30	M10×1.25	22	17	6	32	8	10	10	12	M24×2.0	14	27	14	1/8"	8
40	41.5	20	16	32	M12×1.25	24	17	7	41	9	14	12	12	M30×2.0	14	27	14	1/8"	8

MTA  $\Phi 16\sim\Phi 40$

CA Type

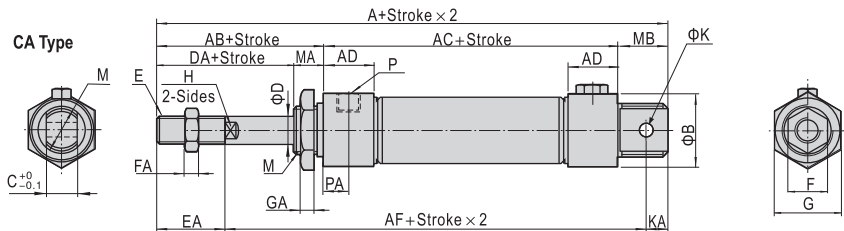

CM Type

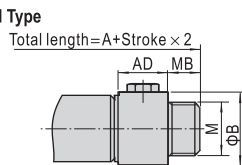

U Type

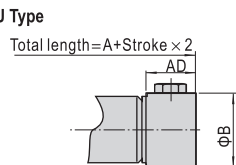

Item	CA		A			U			AC			AF								
Back cover	CA		CM			U			AC			AF								
Bore size\Stroke	≤25	≤50	≤75	≤100	≤25	≤50	≤75	≤100	≤25	≤50	≤75	≤100	≤25	≤50	≤75	≤100				
16	129	139	154	164	129	139	154	164	113	123	138	148	75	85	100	110	106	116	131	141
20	152	162	177	187	143	153	168	178	131	141	156	166	91	101	116	126	123	133	148	158
25	156	166	181	191	149	159	174	184	135	145	160	170	91	101	116	126	125	135	150	160
32	162	172	192	192	149	159	179	179	135	145	165	165	91	101	121	121	128	138	158	168
40	164	174	194	204	151	161	181	191	137	147	167	177	91	101	121	131	128	138	158	168

Bore size\Item	AB	AD	B	C	D	DA	E	EA	F	FA	G	GA	H	K	KA	M	MA	MB	P	PA	
Back cover	AB	AD	B	C	D	DA	E	EA	F	FA	G	GA	H	K	KA	M	MA	CA	CM	P	PA
16	38	10	21	12	6	22	M6×1.0	16	10	5	22	6	5	6	7	M16×1.5	16	16	16	M5×0.8	5
20	40	16	27	16	8	28	M8×1.25	20	12	6	29	7	6	8	9	M22×1.5	12	21	12	1/8"	8
25	44	16	30	16	10	30	M10×1.25	22	17	6	29	7	8	8	9	M22×1.5	14	21	14	1/8"	8
32	44	16	35	16	12	30	M10×1.25	22	17	6	32	8	10	10	12	M24×2.0	14	27	14	1/8"	8
40	46	16.5	41.5	20	16	32	M12×1.25	24	17	7	41	9	14	12	12	M30×2.0	14	27	14	1/8"	8



# Mini cylinder(Stainless steel)

## MA Series

### MAD, MACD

Φ16~Φ40

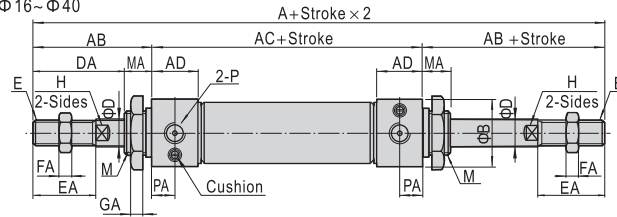

Φ50, Φ63

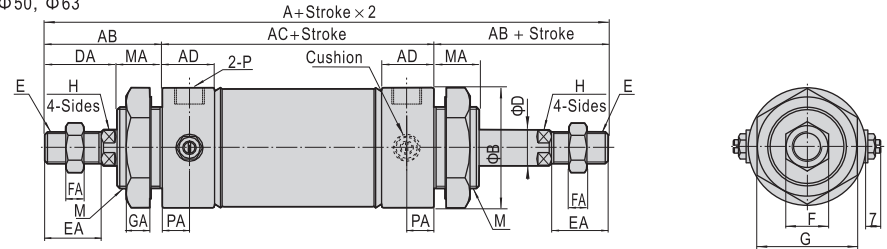

Bore size\Item	A	AB	AC	AD	B	D	DA	E	EA	F	FA	G	GA	H	M	MA	P	PA
16	136	38	60	10	21	6	22	M6 × 1.0	16	10	5	22	6	5	M16 × 1.5	16	M5 × 0.8	5
20	156	40	76	16	27	8	28	M8 × 1.25	20	12	6	29	7	6	M22 × 1.5	12	1/8"	8
25	164	44	76	16	30	10	30	M10 × 1.25	22	17	6	29	7	8	M22 × 1.5	14	1/8"	8
32	164	44	76	16	35	12	30	M10 × 1.25	22	17	6	32	8	10	M24 × 2.0	14	1/8"	8
40	168	46	76	16.5	41.5	16	32	M12 × 1.25	24	17	7	41	9	14	M30 × 2.0	14	1/8"	8
50	199	52	95	23	53	16	32	M14 × 1.5	24	19	8	46	11	14	M36 × 2.0	20	1/4"	11.5
63	199	52	95	23	67	16	32	M14 × 1.5	24	19	8	46	11	14	M36 × 2.0	20	1/4"	11.5

### MAJ, MACJ

Φ16~Φ40

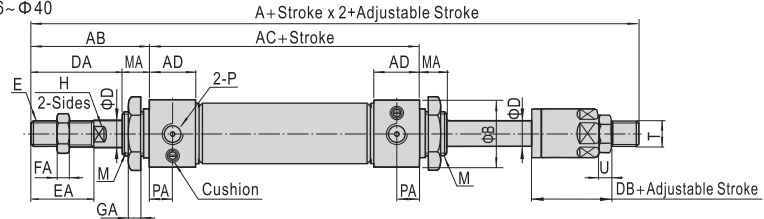

Φ50, Φ63

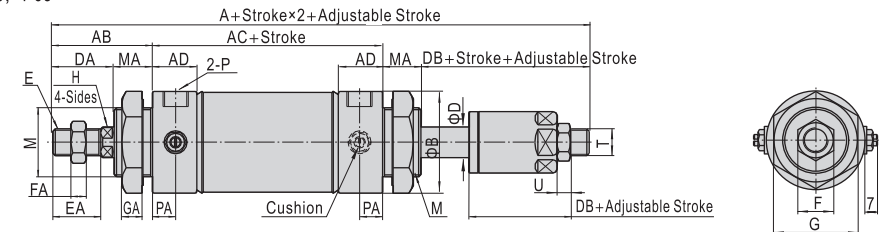

Bore size\Item	A	AB	AC	AD	B	D	DA	DB	E	EA	F	FA
16	135	38	60	10	21	6	22	21	M6 × 1.0	16	10	5
20	153	40	76	16	27	8	28	25	M8 × 1.25	20	12	6
25	161	44	76	16	30	10	30	27	M10 × 1.25	22	17	6
32	161	44	76	16	35	12	30	27	M10 × 1.25	22	17	6
40	164	46	76	16.5	41.5	16	32	28	M12 × 1.25	24	17	7
50	195	52	95	23	53	16	32	28	M14 × 1.5	24	19	8
63	195	52	95	23	67	16	32	28	M14 × 1.5	24	19	8

Bore size\Item	H	M	MA	P	PA	G	GA	T	U
16	5	M16 × 1.5	16	M5 × 0.8	5	22	6	M6 × 1.0	5
20	6	M22 × 1.5	12	1/8"	8	29	7	M8 × 1.25	6
25	8	M22 × 1.5	14	1/8"	8	29	7	M10 × 1.25	6
32	10	M24 × 2.0	14	1/8"	8	32	8	M10 × 1.25	6
40	14	M30 × 2.0	14	1/8"	8	41	9	M12 × 1.25	7
50	14	M36 × 2.0	20	1/4"	11.5	46	11	M12 × 1.25	7
63	14	M36 × 2.0	20	1/4"	11.5	46	11	M12 × 1.25	7

Back  
MA



# Mini cylinder(Stainless steel)

## MA Series

### MARU(Up mounting type)

Φ20~Φ40

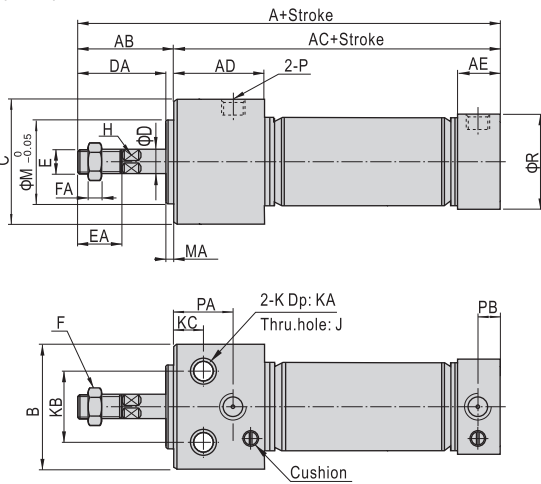

Bore size\Item	A	AB	AC	AD	AE	B	C	D	DA	E	EA
20	120	31	89	29	16	33.5	30.5	8	28	M8 × 1.25	20
25	122	33	89	29	16	39	36.5	10	30	M10 × 1.25	22
32	122	33	89	29	16	47	42.5	12	30	M10 × 1.25	22
40	132.5	35	97.5	37.5	16.5	58.5	52.5	16	32	M14 × 1.5	24

Bore size\Item	F	FA	H	J	K	KA	KB	KC	M	MA	P	PA	PB	R
20	13	5	6	Φ5.5	Φ9.5	6.5	21	12	20	3	1/8"	22	8	27
25	17	6	8	Φ6.5	Φ11.0	7.5	25	12	26	3	1/8"	22	8	30
32	17	6	10	Φ9.0	Φ14.0	10	30	12	26	3	1/8"	22	8	35
40	19	8	14	Φ11	Φ17.5	12.5	38	15	32	3	1/8"	27	8	41.5

### MARF(Front mounting type)

Φ20~Φ40

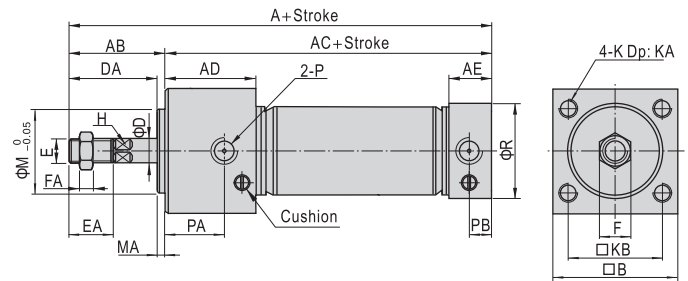

Bore size\Item	A	AB	AC	AD	AE	B	D	DA	E	EA
20	120	31	89	29	16	30.5	8	28	M8 × 1.25	20
25	122	33	89	29	16	36.5	10	30	M10 × 1.25	22
32	122	33	89	29	16	42.5	12	30	M10 × 1.25	22
40	132.5	35	97.5	37.5	16.5	52.5	16	32	M14 × 1.5	24

Bore size\Item	F	FA	H	K	KA	KB	M	MA	P	PA	PB	R
20	13	5	6	M5 × 0.8	9	22	20	3	1/8"	22	8	27
25	17	6	8	M6 × 1.0	11	26	26	3	1/8"	22	8	30
32	17	6	10	M6 × 1/8"	11	30	26	3	1/8"	22	8	35
40	19	8	14	M8 × 1.25	14	36	32	3	1/8"	27	8	41.5

Φ50, Φ63

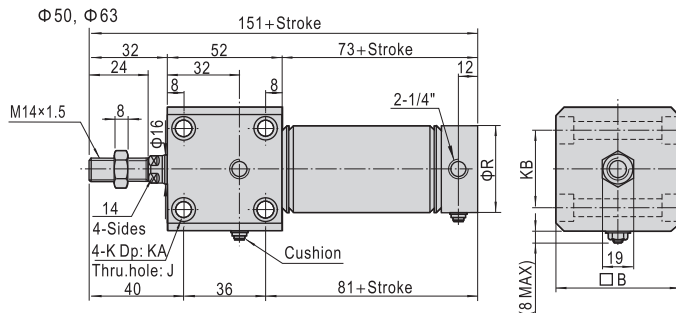

Bore size\Item	B	J	K	KA	KB	R
50	62	Φ6.5	Both sides: Φ11.0	6.5	44	53
63	74	Φ9.0	Both sides: Φ14.0	8.5	48	67

Φ50, Φ63

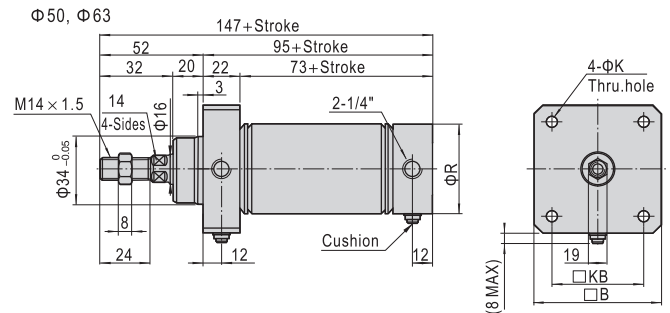

Bore size\Item	B	K	KB	R
50	62	6.5	48	53
63	74	9.0	58	67



# Mini cylinder(Stainless steel)

## Accessories

### Ordering code

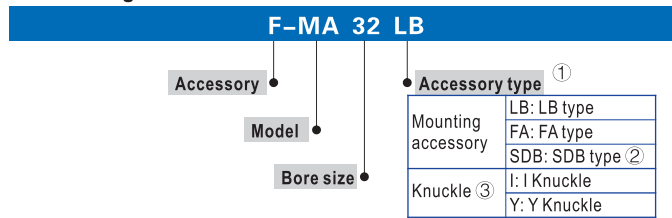

- ① Please refer to accessory list for selection and ordering information.
- ② SDB is attached with relevant PIN.
- ③ Please refer to page 395, 396 for other knuckles.

### Accessory selection

Accessories\Cylinder model	MA, MAC	MSA, MTA	MAD, MACD	MAJ, MACJ	MAR
Mounting accessory	LB	●	●	●	×
	FA	●	●	●	×
	SDB	●	●	×	×
Knuckle ①	I	●	●	●	●
	Y	●	●	●	●
	U	●	●	●	●
	F	●	●	●	●
Sensor switch ②	CS1-M	●	●	●	●
	DS1-M	●	●	●	●
	CS1-F	●	●	●	●
	DS1-F	●	●	●	●
	CS1-U	●	●	●	●
	DS1-U	●	●	●	●

- ① Please refer to P393~396 for knuckle detail.
- ② Please refer to P397~420 for detail of sensor switch.

### Material of accessories

Accessories	Mounting accessories			Knuckle			
	LB	FA	SDB	I	Y	F	U
Bore size	LB	FA	SDB	I	Y	F	U
16-63	○	○	○	□	□	□	□

○ — Low carbon steel, □ — Carbon steel.

### List for ordering code of accessories

Accessories	Mounting accessory		
	LB	FA	SDB
Bore size	LB	FA	SDB
16	F-MA16LB	F-MA16FA	F-MA16SDB
20	F-MA20LB	F-MA20FA	F-MA20SDB
25	F-MA25LB	F-MA25FA	F-MA25SDB
32	F-MA32LB	F-MA32FA	F-MA32SDB
40	F-MA40LB	F-MA40FA	F-MA40SDB
50	-	-	F-MA40SDB
63	-	-	F-MA40SDB

Accessories	Knuckle			
	I: I Knuckle	Y: Y Knuckle	F: F Knuckle	U: U Knuckle
Bore size	I: I Knuckle	Y: Y Knuckle	F: F Knuckle	U: U Knuckle
16	F-MA16I	F-MA16Y	F-M6X100F	F-M6X100U
20	F-MA20I	F-MA20Y	F-M8X125F	F-M8X125U
25	F-MA25I	F-MA25Y	F-M10X125F	F-M10X125U
32	F-MA32I	F-MA32Y	F-M12X125F	F-M12X125U
40	F-MA40I	F-MA40Y	F-M12X125F	F-M12X125U
50	F-MA50I	F-MA50Y	F-M14X150F	F-M14X150U
63	F-MA63I	F-MA63Y	F-M14X150F	F-M14X150U

Accessories	Sensor switch			
	CS1-M	DS1-M	CS1-F	DS1-F
Bore size	CS1-M	DS1-M	CS1-F	DS1-F
16	CS1-M-S16	DS1-M-S16	-	-
20	CS1-M-S20	DS1-M-S20	-	-
25	CS1-M-S25	DS1-M-S25	-	-
32	CS1-M-S32	DS1-M-S32	-	-
40	CS1-M-S40	DS1-M-S40	-	-
50	CS1-M-S50	DS1-M-S50	CS1-F	DS1-F
63	CS1-M-S63	DS1-M-S63	CS1-F	DS1-F

### Dimensions

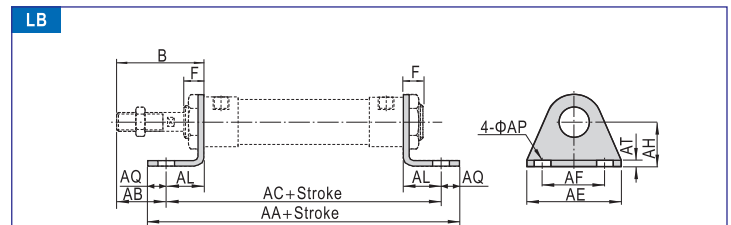

Bore size\Item	AA		AA(MSA)		AC		AC(MSA)	
	(MA)	0~50	51~100	101~150	(MA)	0~50	51~100	101~150
16	98	123	148	-	86	111	136	-
20	122	147	172	197	106	131	156	181
25	122	147	172	197	106	131	156	181
32	142	167	192	217	126	151	176	201
40	142	167	192	217	126	151	176	201

Bore size\Item	B	F	AB	AE	AF	AL	AQ	AP	AT	AH
	16	38	16	25	44	32	13	6	5.5	3
20	40	12	25	54	40	15	8	6.5	3	25
25	44	14	29	54	40	15	8	6.5	3	25
32	44	14	19	59	45	25	8	6.5	4	32
40	46	14	21	64	50	25	8	6.5	4	36

### FA

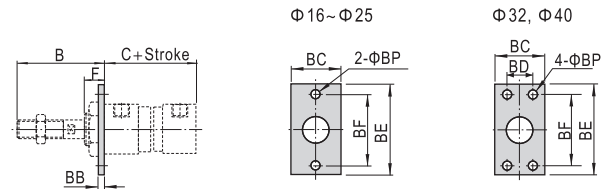

Bore size\Item	Stroke	B	C	C(MSA)			BB	BC	BD	BE	BF	BP	F
		(MA)	0~50	51~100	101~150	BB	BC	BD	BE	BF	BP	F	
16	38	60	85	110	-	3	26	-	52	40	5.5	16	
20	40	76	101	126	151	4	38	-	64	50	6.5	12	
25	44	76	101	126	151	4	38	-	64	50	6.5	14	
32	44	76	101	126	151	4	47	33	72	58	6.5	14	
40	46	76	101	126	151	4	50	36	84	70	6.5	14	

### SDB

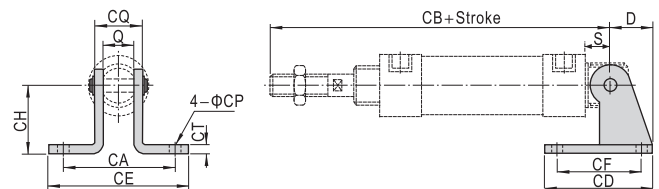

Bore size\Item	Stroke	D	S	Q	CA	CB	CB(MSA)			CD	CE	CF	CH	CT	CP	CQ
		(MA)	0~50	51~100	101~150	CD	CE	CF	CH	CT	CP	CQ				
16	16	9	12	-	107	132	157	-	23	-	12	20	2	5.5	16	
20	21	12	16	51	128	153	178	203	48	67	32	32	3	6.5	22	
25	21	12	16	51	132	157	182	207	48	67	32	32	3	6.5	22	
32	27	15	16	51	135	160	185	210	52	67	36	36	4	6.5	24	
40	27	15	20	55	137	162	187	212	56	71	40	40	4	6.5	28	

# Mini cylinder(Stainless steel)

## Accessories

### I Knuckle

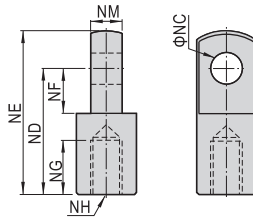

Type\Item	NC	ND	NE	NF	NG	NH	NM
F-MA16I	5	21	28	8.5	8	M6×1.0	6
F-MA20I	8	30	40	11	15	M8×1.25	8
F-MA25I	10	40	50	15	20	M10×1.25	10
F-MA40I	10	45	57	16	23	M12×1.25	14

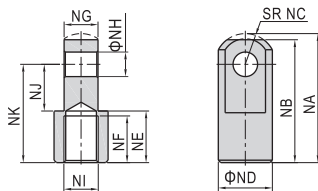

Type\Item	NA	NB	NC	ND	NE	NF	NG	NH	NJ	NK	NI
F-MAC50I	52.5	50	12.5	22	21	19	13.8	10	19	40	M14×1.5

### Y Knuckle

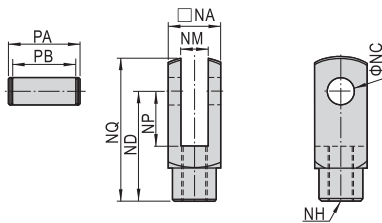

Type\Item	NA	NC	ND	NP	NQ	NM	NH	PA	PB
F-MA16Y	12	5	21	8.5	27.4	6	M6×1.0	16.8	12.4
F-MA40Y	25.4	10	45	20	57	14	M12×1.25	32	26.2

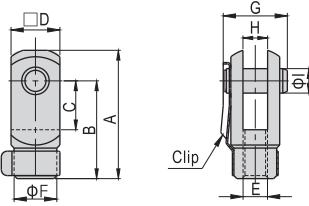

Type\Item	A	B	C	D	E	F	G	H	I
F-MA20Y	42	32	16	16	M8×1.25	14	21	8	8
F-MA25Y	52	40	20	19	M10×1.25	18	25	10	10

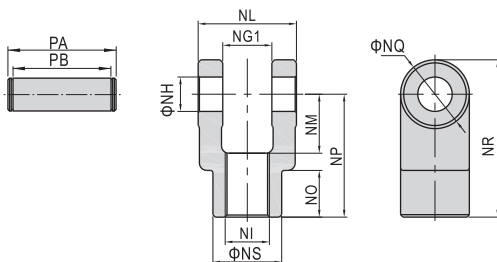

Type\Item	NG1	NH	NI	NL	NM	NO	NP	NQ	NR	NS	PA	PB
F-MAC50Y	14.2	10	M14×1.5	27.8	19	17	40	22	51	22	34.6	28.8

